



Model Number

RC15-14-N3

Features

- 15 mm inside diameter
- Bistable
- Direction detection
- High passage speed
10 m/s

Technical Data

General specifications

Switching function	Normally closed (NC)
Output type	NAMUR, bistable
Inside diameter	15 mm
Measuring cylinder	Fe-metal
Diameter	3 mm
Length	4 mm
Passage speed	v ≤ 10 m/s
Output type	2-wire

Nominal ratings

Nominal voltage	U_o	8.2 V (R_i approx. 1 k Ω)
Operating voltage	U_B	5 ... 25 V
Hysteresis	H	typ. 1 %
Reverse polarity protection		reverse polarity protected

Design data

Current consumption		
Traverse B		3 mA
Traverse A		1 mA
Time delay before availability	t_v	≤ 5 ms

Functional safety related parameters

MTTF _d	2240 a
Mission Time (T_M)	20 a
Diagnostic Coverage (DC)	0 %

Ambient conditions

Ambient temperature	-20 ... 70 °C (-4 ... 158 °F)
Storage temperature	-40 ... 100 °C (-40 ... 212 °F)

Mechanical specifications

Connection type	cable PVC, 2 m
Core cross-section	0.14 mm ²
Housing material	PBT
Degree of protection	IP67
Cable	
Bending radius	> 10 x cable diameter

General information

Use in the hazardous area	see instruction manuals
Category	2G

Compliance with standards and directives

Standard conformity	
NAMUR	EN 60947-5-6:2000 IEC 60947-5-6:1999
Standards	EN 60947-5-2:2007 IEC 60947-5-2:2007

Approvals and certificates

FM approval	
Control drawing	116-0165F
UL approval	cULus Listed, General Purpose
CSA approval	cCSAus Listed, General Purpose

Dimensions

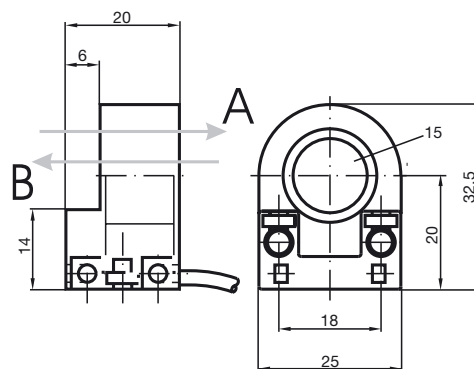

Electrical Connection

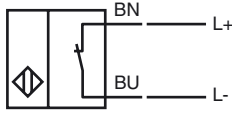

Equipment protection level Gb

CE marking	CE 0102	
ATEX marking	Ex II 2G Ex ia IIC T6...T1 Gb The Ex-related marking can also be printed on the enclosed label.	
Standards	EN 60079-0:2012+A11:2013, EN 60079-11:2012 Ignition protection "Intrinsic safety" Use is restricted to the following stated conditions	
Appropriate type	RC15-...-N3...	
Effective internal inductivity	C_i	$\leq 90 \text{ nF}$; a cable length of 10 m is considered.
Effective internal inductance	L_i	$\leq 70 \text{ }\mu\text{H}$; a cable length of 10 m is considered.
Maximum permissible ambient temperature T_{amb}	Details of the correlation between the type of circuit connected, the maximum permissible ambient temperature, the temperature class, and the effective internal reactance values can be found on the EU-type examination certificate.	
Special conditions		

Release date: 2017-07-27 14:00 Date of issue: 2018-02-16 051667_eng.xml